

Exhaust Gas Recirculation Valve Cooler Cleaning and Inspection

Cleaning Procedure

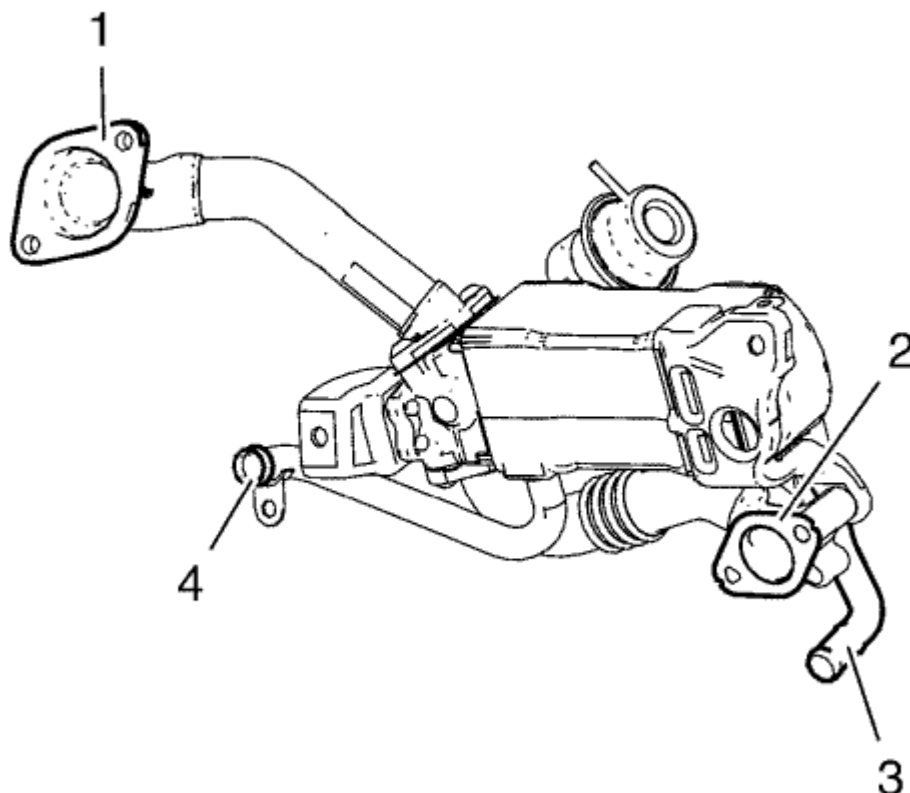

1. Clean the exhaust gas recirculation valve tube flange (1) of dirt and old gasket material.
2. Clean the bypass valve flange (2) of dirt and old gasket material.
3. Clean the coolant hose attachment (3).
4. Clean the sealing groove of the thermostat housing tube (4).

Visual Inspection

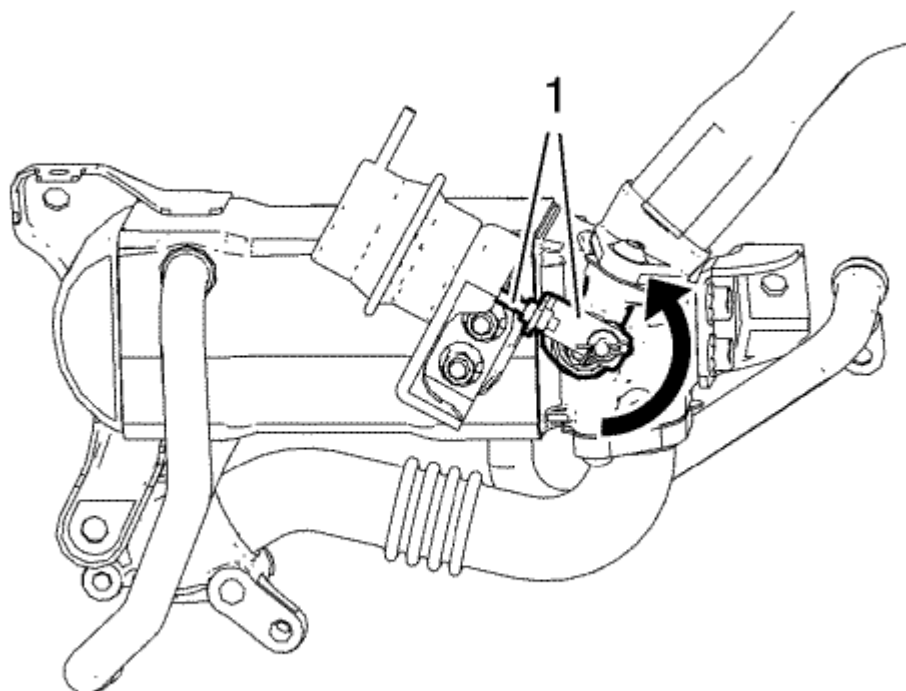

Inspect the exhaust gas recirculation cooler vacuum actuator mechanism (1) for practicability by rotating as shown.

If the exhaust gas recirculation cooler vacuum actuator mechanism is not practicable, replace the exhaust gas recirculation cooler.